

## Installation, Operating, Inspection and Maintenance Instructions Ladder Climber's Safety System

Model #'s: 6000, 6001, 6010



### Warning

You must read and fully understand all instructions, or have all instructions explained to you, before attempting to use this device. Equipment must not be installed, operated or inspected by anyone who does not understand these instructions. Failure to observe these instructions could result in serious injury or death. Careless or improper use of this equipment can result in serious injury or death. Training and instruction review should be repeated at regular intervals. Keep these instructions available for immediate reference. If you have any questions regarding these instructions or need additional copies, call Gemtor toll free at 800-405-9048.

**IMPORTANT: THESE INSTRUCTIONS SHOULD BE  
ACCESSIBLE TO THE USER AT ALL TIMES.**

## Important Information:

**Purchased from (Distributor):** \_\_\_\_\_

**Address:** \_\_\_\_\_

\_\_\_\_\_

**City:** \_\_\_\_\_ **State** \_\_\_\_\_ **Zip** \_\_\_\_\_

**Purchase Date:** \_\_\_\_\_

**Model Number:** \_\_\_\_\_

**Serial Number:** \_\_\_\_\_

**Property of:**

\_\_\_\_\_

\_\_\_\_\_

\_\_\_\_\_

\_\_\_\_\_

\_\_\_\_\_

**Keep this information for future reference.**

## INSTALLATION TO UPRIGHT STRUCTURES:

These instructions apply to Ladder Climber's Safety System installations to upright structures, equipped with either a fixed ladder or side rungs (such as on poles).

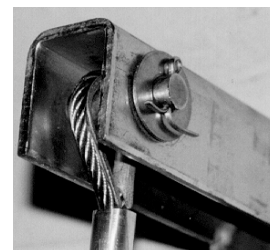

**Step 1**

All component parts and assemblies referred to in these installation instructions are furnished without additional charge. The top and bottom support brackets are furnished with clamping plates and stainless steel bolts, nuts and lock washers. All parts are plated steel except where otherwise indicated.

Installation should be made along the centerline of the ladder.

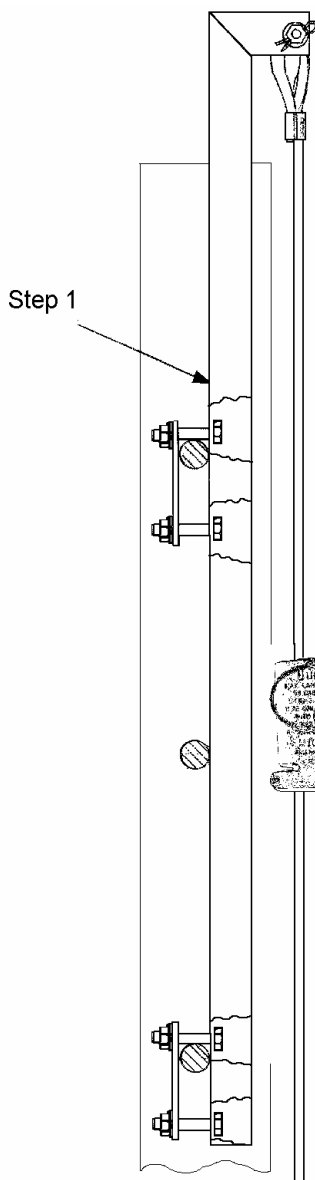

### STEP 1:

Attach the top cable support bracket to the first and third rungs from top. Secure the swaged eye at the end of the stainless steel cable to the top bracket using the stainless steel clevis pin. Insert the cotter pin into the clevis pin and bend the ends of the cotter pin over.

### STEP 2:

Attach the lower cable support bracket to two rungs, as low as possible.

### STEP 3:

Attach the cable to the eye of the turnbuckle using the wire rope thimble and wire rope clips provided. Attach the top of the tension spring to the jaw of the turnbuckle with the provided shackle. Attach the bottom of spring to the bracket with bolt and nut. Hand-tighten the turnbuckle to take up any slack in the cable. The cable should be taut. The spring compensates for expansion and contraction of the cable.

### STEP 4:

Attach cable guides to rungs at 35 ft. intervals. Insert the cable into the guides. The guides prevent wind lashing of the cable.

### SPECIAL NOTE FOR LADDERS WITH OBTUSE ANGLE

Where ladder is not completely in line, but has an obtuse angle (as illustrated), install cable guide and insert cable (step 4) where ladder begins to angle before anchoring cable (step 3). When ordering for obtuse angled ladders, determine the length of cable required by measuring exact length of ladder, not the height of structure.

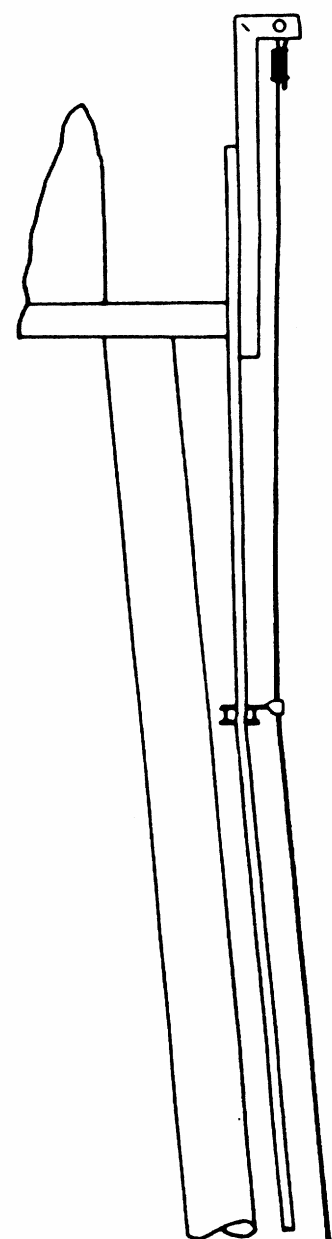
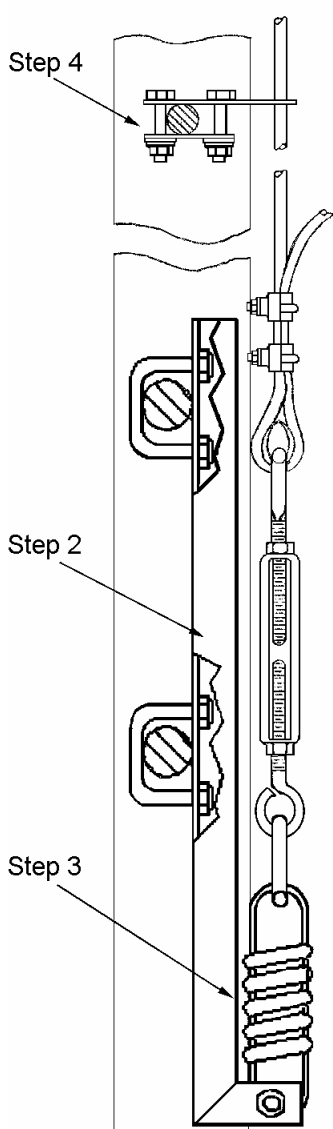

## DESCRIPTION AND GENERAL INFORMATION:

The Gemtor 6000 series Ladder Climber's Safety System is designed to reduce the possibility of a worker's fall while climbing a fixed permanently installed ladder. The sleeve is designed to follow a worker's movement as he/she climbs up and down a ladder. If the worker slips, the sleeve immediately locks on the cable, reducing the possibility of serious injury.

Gemtor manufactures a complete line of high quality belts, harnesses and safety devices for specific requirements. Consult the attached caution label and all supplied information indicating recommended usage. Refer to page 3 of this owner's manual for installation instructions.

The ladder climber's belt or harness supplied with this unit has been manufactured specifically for use with the Ladder Climber's Safety System (Note: the back D-ring of the harness may be used for fall arrest).

If a Gemtor belt or harness does not fit properly, replace it with the correct size. Do not attempt to alter the belt or harness. Do not alter the system in any way.

Should the belt, harness or device be subjected to impact forces, it should be discarded and replaced.

Belts, harnesses and components of this system should be inspected prior to use. Equipment showing signs of wear or damage must not be used. Replace worn belts, harnesses, cable and components with new Gemtor equipment.

This system is designed to reduce the possibility of falls.

The Model # 6002 Ladder Climber's Safety Sleeve is to be used with the specific 5/16" diameter cable supplied with the system.





Follow all federal, state and local laws regarding this type of personal protective equipment.

## BEFORE EACH USE:

Inspect all components of the Ladder Climber's Safety System. The belt, harness, sleeve, cable, brackets and mounting hardware should be visually inspected for any damage including, but not limited to, cuts, tears, abrasion or breaks. Equipment showing signs of damage or wear must not be used. Replace all worn or damaged components with new Gemtor components only. Cable and sleeve shall be kept free of foreign matter (clean in solvent). The sleeve may be left in solvent overnight. Wipe sleeve clean of solvent before use. **NEVER USE GREASE OR OIL ON THE SLEEVE OR CABLE.**

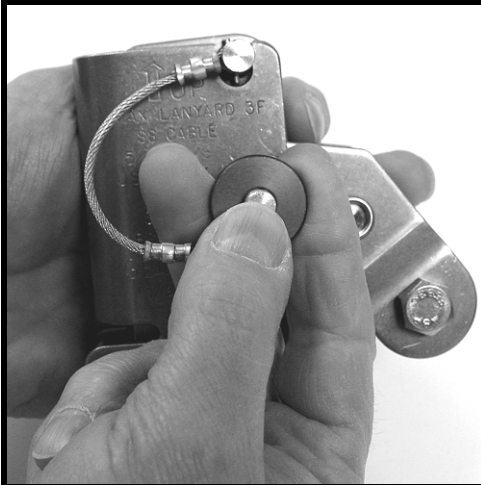

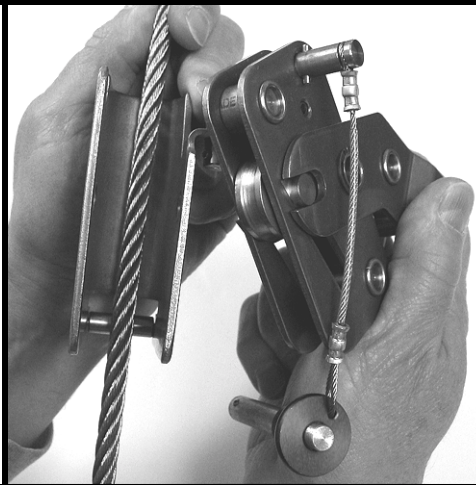
## ATTACHING TO CABLE:

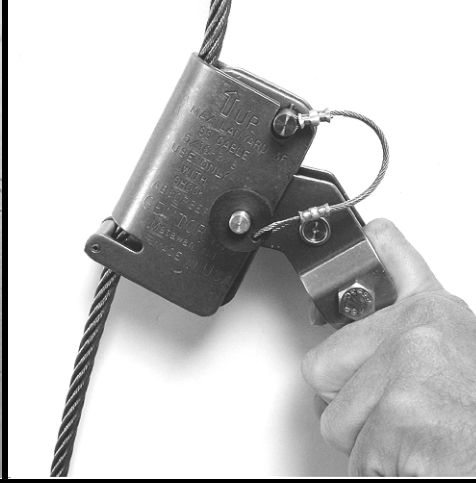
		
<p><b>1) Depress the button on the safety locking pin and remove from main assembly</b></p>	<p><b>2) Swing cam and lever assembly up and open.</b></p>	<p><b>3) Place grab on cable with direction arrow pointing up.</b></p>
		
<p><b>4) Close assembly, align holes and reinsert safety locking pin.</b></p>	<p><b>5) Make sure that locking pin balls appear on outside of main assembly.</b></p>	<p><b>6) Check locking action by yanking down on grab handle.</b></p>

## OPERATING INSTRUCTIONS:



**1) Attach front D-ring of harness or belt to sleeve handle using supplied carabiner.**



**2) Climb up and down ladder in normal manner.**

## WARNINGS:

### DO NOT USE IF:

- The device appears to be damaged.
  - The cable is worn or partially cut.
  - The carabineer does not function properly.
  - The sleeve does not lock on the cable.
  - The unit has arrested a severe fall.
  - The unit has not been formally inspected within the last 6 months.
  - The unit has not been inspected prior to use.
- 
- **DO NOT** attempt to adjust, repair or modify.
  - **DO NOT** use steel cable near electrical lines or equipment.
  - **DO NOT** attach more than one worker to the sleeve.
  - **DO NOT** attach anything (i.e. lanyard, shock absorber) between the sleeve and harness/belt to extend the connection distance beyond its designed length.
  - **DO USE** Gemtor components designed for use with this system only.
  - **DO USE** only the front D-ring of the appropriate Gemtor harness/belt for ladder climbing.

## FORMAL INSPECTION:

The Ladder Climber's Safety System shall be formally inspected by a competent person other than the user at intervals not to exceed 6 months. (The qualifications of a competent person are established by OSHA.) If the product is exposed to severe working conditions, more frequent formal inspections may be required.

## COMPONENT PARTS LIST :

<u>Part#</u>	<u>Description</u>
A-627	5/16" stainless steel cable rail
6002	Ladder climber's safety sleeve (complete with carabiner and shock absorber)
933-2	Ladder climber's harness
A-687	Turnbuckle
5000-241	Tension spring
DL-119	Upper mounting bracket
DL-174	Lower mounting bracket
6006	Cable guide assembly

**IF YOU HAVE ANY QUESTIONS CONCERNING THE  
CORRECT USAGE OF THIS OR ANY GEMTOR  
PRODUCT,  
DO NOT USE, CALL (TOLL FREE) 1-800-405-9048**

INSPECTION LOG:



NOTES:

---

---

---

---

---

---

---

---

---

---

---

---

---

---

---

---

---

---

---

---

---

---

---

---

---

---